

GREASE TRAP (A)

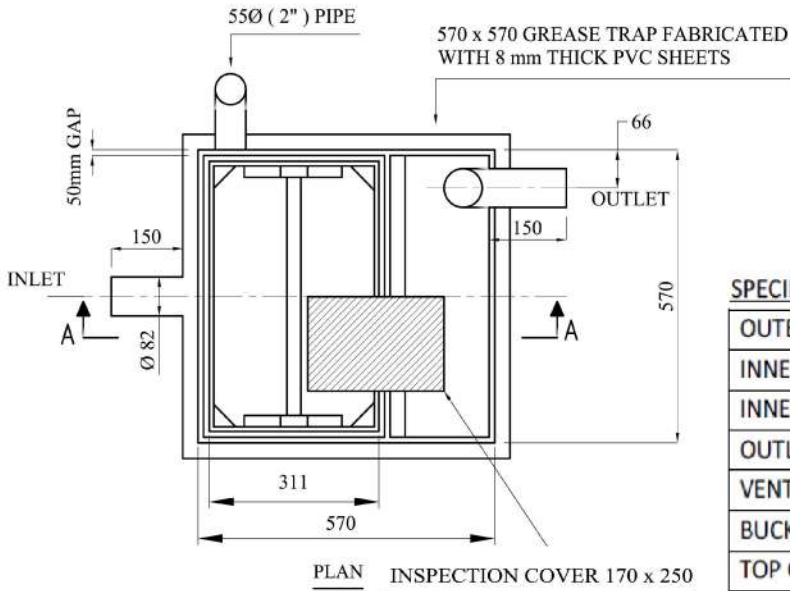
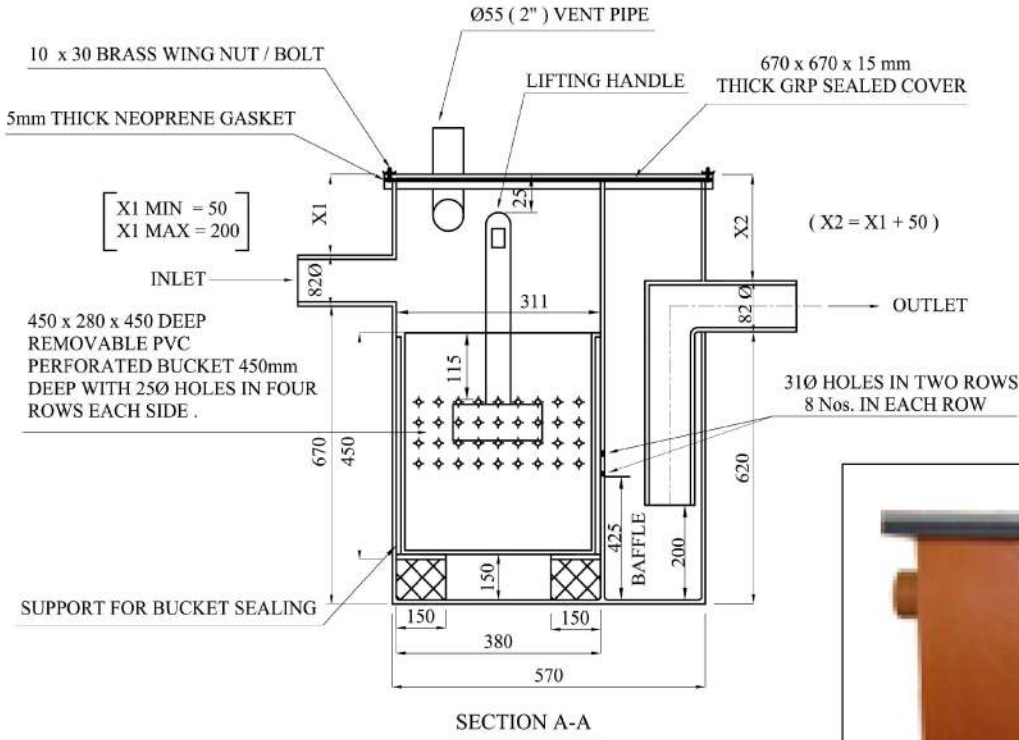

SPECIFICATION :

OUTER BODY	8mm THICK RIGID PVC SHEET BS EN 1401
INNER BUCKET	8mm THICK RIGID PVC SHEET BS EN 1401
INNER PIPE	82mm dia UPVC pipe BS EN 1329
OUTLET PIPE	82mm dia UPVC pipe BS EN 1329
VENT PIPE	55mm dia PVC pipe BS 5255
BUCKET SUPPORT	100x380x150mm Ht. Rigid PVC BS EN 1401
TOP COVER	665x665x15mm H. Duty GRP Cover.
BUCKET HANDLE	50x22x630mm Long Rigid PVC BAR
FLOW RATE	4.4 Ltr / Sec.

NOTE : ALL DIMENSIONS ARE IN MM

Manufactured By:



P. O. Box : 3887. Tel : 06-7660077 . Fax : 06-7660075.
Umm Al Quwain - U.A.E.
Email : fitcouaq@gmail.com

(An ISO 9001 : 2008 Certified Company)

Notes :