

Terminal Protection to IP20



Dims: to DIN 43880
W. 17.5mm

- ***NEW* 17.5mm DIN rail housing**
- **Microprocessor based**
- **True R.M.S. monitoring**
- **7 Selectable Nominal voltage ranges (12 – 240V AC/DC)**
- **Window operation Under and Over voltage monitoring**
- **Adjustable Under and Over voltage trip levels**
- **Adjustable time delay**
- **Isolated Auxiliary supply (24 – 230V AC/DC)¹**
- **1 x SPDT relay output 8A**
- **Green LED indication for supply status**
- **Separate Yellow LED indication for Under or Over voltage condition**



ISO 9001:2015
Cert. No. 14125771

FUNCTION DIAGRAM

Under and Over Voltage Monitoring

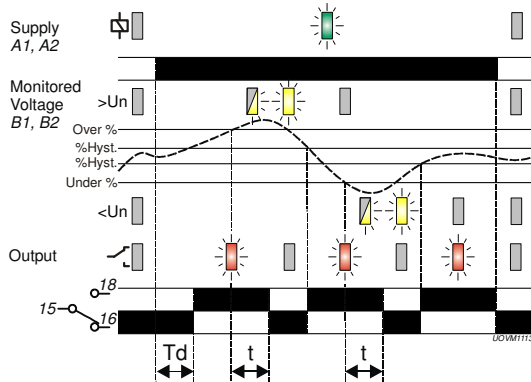

TECHNICAL SPECIFICATION

Auxiliary supply voltage U (A1, A2):	24 – 230V AC/DC ¹ (12 – 60V AC/DC also available)			
Frequency range:	48 - 63Hz (AC supplies)			
Supply variation:	+15% / - 10%			
Overvoltage category:	III (IEC 60664)			
Rated impulse withstand voltage:	4kV (1.2/50µs) IEC 60664			
Power consumption (max.):	24V	48V	115V	230V
	AC: 0.84 VA	0.82 VA	1.1 VA	1.4 VA
	DC: 0.6 W	0.47 W	0.46 W	0.53 W

Monitoring mode:	Under and Over voltage (Window)
Hysteresis:	2% fixed
Selectable nominal voltages (Un):	12, 24, 48, 110, 115, 230, 240V
Under trip level adjustment:	70 – 95% of Un
Over trip level adjustment:	105 – 130% of Un
Time delay (t):	0.1 – 30s (from fault occurring to relay de-energising)
Power up delay (Td):	1 second (fixed)
Reset time:	100ms
Accuracy:	± 1% of maximum full scale
Adjustment accuracy:	< 5% of maximum full scale
Repeat accuracy:	± 0.5% at constant conditions
Drift with temperature:	± 0.05% / °C
Drift with voltage:	± 0.2% / V

Monitoring input (B1, B2):	0.2 to 350V AC/DC
Frequency:	DC, 48 – 500Hz
Maximum input rating:	500V
Overload:	1kV for 1s
Overvoltage category:	III (IEC 60664)
Rated impulse withstand voltage:	4kV (1.2/50µs) IEC 60664
Power on indication:	Green LED
Under voltage trip indication:	Red LED
Over voltage trip indication:	Red LED
Ambient temp:	-20 to +60°C
Relative humidity:	+95%
Output (15, 16, 18):	SPDT relay
Output rating:	AC1 250V 10A (2500VA) AC15 250V 5A (no), 3A (nc) DC1 25V 10A (250W)

Electrical life:	≥ 150,000 ops at rated load
Dielectric voltage:	2kV AC (rms) IEC 60947-1
Rated impulse withstand voltage:	4kV (1.2/50µs) IEC 60664
Housing:	Orange flame retardant UL94 V0
Weight:	63g
Mounting option:	On to 35mm symmetric DIN rail to BS EN 60715 or direct surface mounting via 2 x M3.5 or 4BA screws using the black clips provided on the rear of the unit
Terminal conductor size	≤ 2 x 2.5mm ² solid or stranded

Approvals:	IND. CONT. EQ. E111187 CE and RoHS Compliant. EMC: Immunity: EN 61000-6-2 (EN 61000-4-3 10V/m 80MHz - 2.7GHz) Emissions: EN 61000-6-4
------------	--

INSTALLATION AND SETTING

- BEFORE INSTALLATION, ISOLATE THE SUPPLY.
- Connect the Auxiliary and Monitored Inputs as required.



Installation work must be carried out by qualified personnel.

Setting the unit.

- Set the "Nominal voltage" selector ⑧ to the match that of the voltage being monitored on terminals B1 and B2.
- Set the "Under %" ⑤ and "Over %" ⑦ trip levels as required. These are scaled as a % of the selected nominal voltage.
- Set the "Delay" ⑥ as required.

Applying power.

- Apply power and the green LED ① will illuminate. Both yellow LED's will remain extinguished and the relay will energise. The red LED ② will also illuminate.

Under voltage condition:

- If the monitored voltage falls below the "Under %" trip level the yellow "<Un" LED ③ will start flashing. The relay will de-energise and red LED extinguish after the delay period "t" has elapsed. The yellow LED will then remain illuminated to indicate an under voltage condition. The relay will re-energise/red LED illuminate (and yellow LED extinguish) when the voltage rises above the trip level plus the hysteresis.

Over voltage condition:

- If the monitored voltage rises above the "Over %" trip level the yellow ">Un" LED ④ will start flashing. The relay will de-energise and red LED extinguish after the delay period "t" has elapsed. The yellow LED will then remain illuminated to indicate an over voltage condition. The relay will re-energise/red LED illuminate (and yellow LED extinguish) when the voltage falls below the trip level minus the hysteresis.

CONNECTION DIAGRAM

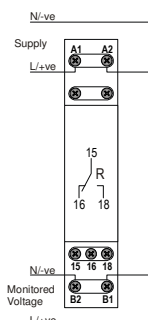

SETTING DETAILS

1. Power supply status (Green) LED
2. Over voltage trip indication (Yellow) LED
3. Under voltage trip indication (Yellow) LED
4. Relay energised (Red) LED
5. Under voltage trip level adjustment
6. Time delay adjustment
7. Over voltage trip level adjustment
8. Nominal voltage selector

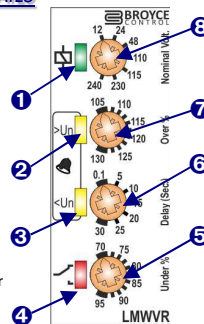

DIMENSIONS

